

## YASKAWA AC Drive-V1000 Option Modbus TCP/IP Installation Manual

Type: SI-EM3/V

To properly use the product, read this manual thoroughly and retain for easy reference, inspection, and maintenance. Ensure the end user receives this manual.

## V1000 オプションユニット Modbus TCP/IP通信 取扱説明書

形 式 SI-EM3/V

製品を安全にお使いいただくために、本書を必ずお読みください。  
また、本書をお手元に保管していただくとともに、最終的に本製品をご使用になるユーザー様のお手元に確実に届けられるよう、お取り計らい願います。

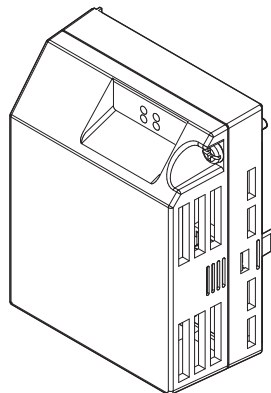

---

## **Copyright © 2012 YASKAWA ELECTRIC CORPORATION**

All rights reserved. No part of this publication may be reproduced, stored in a retrieval system, or transmitted, in any form or by any means, mechanical, electronic, photocopying, recording, or otherwise, without the prior written permission of Yaskawa. No patent liability is assumed with respect to the use of the information contained herein. Moreover, because Yaskawa is constantly striving to improve its high-quality products, the information contained in this manual is subject to change without notice. Every precaution has been taken in the preparation of this manual. Yaskawa assumes no responsibility for errors or omissions. Neither is any liability assumed for damages resulting from the use of the information contained in this publication.

# Table of Contents

---

<b>1</b>	<b>PREFACE AND SAFETY</b> .....	<b>4</b>
<b>2</b>	<b>OVERVIEW</b> .....	<b>9</b>
<b>3</b>	<b>RECEIVING</b> .....	<b>11</b>
<b>4</b>	<b>OPTION COMPONENTS</b> .....	<b>12</b>
<b>5</b>	<b>INSTALLATION PROCEDURE</b> .....	<b>17</b>
<b>6</b>	<b>RELATED DRIVE PARAMETERS</b> .....	<b>30</b>
<b>7</b>	<b>MODBUS TCP/IP MESSAGING</b> .....	<b>34</b>
<b>8</b>	<b>WEB INTERFACE</b> .....	<b>39</b>
<b>9</b>	<b>TROUBLESHOOTING</b> .....	<b>42</b>
<b>10</b>	<b>EUROPEAN STANDARDS</b> .....	<b>47</b>
<b>11</b>	<b>SPECIFICATIONS</b> .....	<b>49</b>

# 1 Preface and Safety

YASKAWA Electric supplies component parts for use in a wide variety of industrial applications. The selection and application of YASKAWA products remain the responsibility of the equipment designer or end user.

YASKAWA accepts no responsibility for the way its products are incorporated into the final system design. Under no circumstances should any YASKAWA product be incorporated into any product or design as the exclusive or sole safety control. Without exception, all controls should be designed to detect faults dynamically and fail safely under all circumstances. All products designed to incorporate a component part manufactured by YASKAWA must be supplied to the end user with appropriate warnings and instructions as to the safe use and operation of that part. Any warnings provided by YASKAWA must be promptly provided to the end user. YASKAWA offers an express warranty only as to the quality of its products in conforming to standards and specifications published in the manual. **NO OTHER WARRANTY, EXPRESS OR IMPLIED, IS OFFERED.** YASKAWA assumes no liability for any personal injury, property damage, losses, or claims arising from misapplication of its products.

### ◆ Applicable Documentation

The following manuals are available for the option and drive:

#### Option

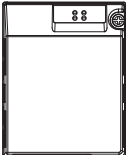
	<b>YASKAWA AC Drive -V1000 Option SI-EM3/V Modbus TCP/IP Installation Manual Manual No: TOEP C730600 59</b>	Read this manual first. The installation manual is packaged with the option and contains a basic overview of wiring, settings, functions, and fault diagnoses.
	<b>YASKAWA AC Drive -V1000 Option SI-EM3/V Modbus TCP/IP Technical Manual Manual No: SIEP C730600 59 (This book)</b>	The technical manual contains detailed information and command registers. To obtain the technical manual access these sites: U.S.: <a href="http://www.yaskawa.com">http://www.yaskawa.com</a> Europe: <a href="http://www.yaskawa.eu.com">http://www.yaskawa.eu.com</a> Japan: <a href="http://www.e-mechatronics.com">http://www.e-mechatronics.com</a> Other areas: contact a Yaskawa representative.

## Yaskawa Drive

	<b>YASKAWA AC Drive-V1000 Quick Start Guide</b>	To obtain instruction manuals for Yaskawa products access these sites: U.S.: <a href="http://www.yaskawa.com">http://www.yaskawa.com</a> Europe: <a href="http://www.yaskawa.eu.com">http://www.yaskawa.eu.com</a> Japan: <a href="http://www.e-mechatronics.com">http://www.e-mechatronics.com</a> Other areas: contact a Yaskawa representative.
	<b>YASKAWA AC Drive-V1000 Technical Manual</b>	For questions, contact the local Yaskawa sales office or the nearest Yaskawa representative.

## ◆ Terms

<b>Note:</b>	Indicates a supplement or precaution that does not cause drive damage.
<b>Drive:</b>	YASKAWA AC Drive-V1000 Series.
<b>Modbus TCP/IP Option:</b>	YASKAWA AC Drive-V1000 Option SI-EM3/V Modbus TCP/IP
<b>≥ 1012:</b>	Indicates a drive feature or function that is only available in drive software version 1012 or greater.
<b>H (Example: 900H)</b>	Indicates an engineering unit for hexadecimal number format.

## ◆ Registered Trademarks

- Modbus TCP/IP is a trademark of Modbus-IDA.
- All trademarks are the property of their respective owners.

# 1 Preface and Safety

---

## ◆ Supplemental Safety Information

Read and understand this manual before installing, operating, or servicing this option. The option must be installed according to this manual and local codes.

The following conventions are used to indicate safety messages in this manual. Failure to heed these messages could result in serious or possibly even fatal injury or damage to the products or to related equipment and systems.

### **DANGER**

Indicates a hazardous situation, which, if not avoided, will cause death or serious injury.

### **WARNING**

Indicates a hazardous situation, which, if not avoided, could cause death or serious injury.

### **CAUTION**

Indicates a hazardous situation, which, if not avoided, could cause minor or moderate injury.

### **NOTICE**

Indicates an equipment damage message.

## ■ General Safety

### General Precautions

- The diagrams in this section may include options and drives without covers or safety shields to illustrate details. Reinstall covers or shields before operating any devices. The option should be used according to the instructions described in this manual.
- The diagrams in this manual are provided as examples only and may not pertain to all products covered by this manual.
- The products and specifications described in this manual or the content and presentation of the manual may be changed without notice to improve the product and/or the manual.
- Contact a Yaskawa representative or the nearest Yaskawa sales office and provide the manual number shown on the front cover to order new copies of the manual.

### DANGER

#### **Heed the safety messages in this manual.**

Failure to comply will cause death or serious injury.

The operating company is responsible for any injuries or equipment damage resulting from failure to heed the warnings in this manual.

### WARNING

#### **Electrical Shock Hazard**

**Do not attempt to modify or alter the drive or drive circuitry in any way not explained in this manual.**

Failure to comply could cause death or serious injury and will void warranty. Yaskawa is not responsible for any modification of the product made by the user. Do not modify this product.

### NOTICE

**Do not expose the drive or the option to halogen group disinfectants. Do not pack the drive or the option in fumigated or sterilized wooden materials. Do not sterilize the entire package after packing the product.**

Failure to comply could damage electrical components in the option.

# 1 Preface and Safety

## ■ Option Unit Warning Labels

Warning information is displayed on the option unit as shown in the figure below. Follow all warnings and safety instructions when using the product.

When using the drive in an area that may require displaying warning information in Japanese or Chinese, a warning label is provided with the option. This label can be placed over the English and French warnings on the front of the option.

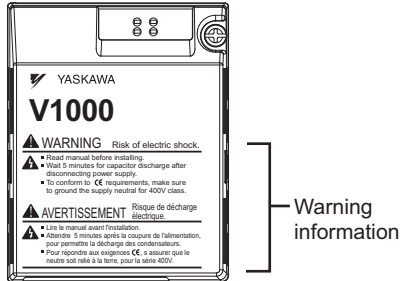

## ■ Warning Contents

### **WARNING** Risk of electric shock.

-  Read manual before installing.
- Wait 5 minutes for capacitor discharge after disconnecting power supply.
- To conform to **CE** requirements, make sure to ground the supply neutral for 400V class.

### **AVERTISSEMENT** Risque de décharge électrique.

-  Lire le manuel avant l'installation.
- Attendre 5 minutes après la coupure de l'alimentation, pour permettre la décharge des condensateurs.
- Pour répondre aux exigences **CE**, s'assurer que le neutre soit relié à la terre, pour la série 400V.



## 2 Overview

This option provides a communications connection between the drive and a Modbus TCP/IP network. The option connects the drive to a Modbus TCP/IP network and facilitates the exchange of data.

This manual explains the handling, installation and specifications of this product.

The option is a communications link to connect industrial devices (such as smart motor controllers, operator interfaces, and variable frequency drives) as well as control devices (such as programmable controllers and computers) to a network. The option is a simple, networking solution that reduces the cost and time to wire and install factory automation devices, while providing interchangeability of like components from multiple vendors.

Install the option/Modbus TCP/IP option on a drive to perform the following functions from a Modbus TCP/IP master device:

- Operate the drive
- Monitor the drive operation status
- Change drive parameter settings

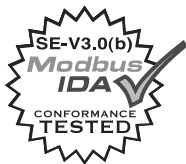

## 2 Overview

---

### ◆ Compatible Products

The option can be used with the products in [Table 1](#).

**Table 1 Compatible Products**

Product Series	Model(s)	Software Version <1>
V1000	CIMR-V□□A□□□□	≥ 1012

**Note:** For Yaskawa customers in the North or South America region:  
If your product is not listed in [Table 1](#), refer to the web page below to confirm this manual is correct for your product. The web page provides a list of option manuals by product, and a direct link to download a PDF.

**Scan QR code**



Or refer to: <http://www.yaskawa.com/optionlookup>

## 3 Receiving

After receiving the option package:

1. Make sure that the option is not damaged and no parts are missing. Contact your sales outlet if the option or other parts appear damaged.

**NOTICE:** Do not use damaged parts to connect the drive and the option. Failure to comply could damage the drive and option.

2. Confirm that the model number on the option nameplate and the model listed in the purchase order are the same. Refer to **Figure 1** on page **12** for details. Contact the distributor where the option was purchased or the Yaskawa sales office immediately about any problems with the option.

### ◆ Option Package Contents

Table 2 Option Package Contents

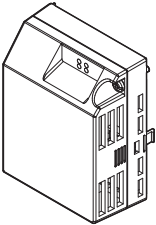
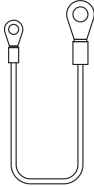
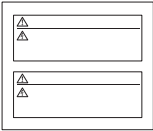
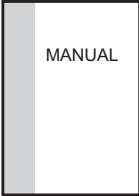
Description:	Option Unit	Ground Wire	Warning Labels	Installation Manual
-				
<b>Quantity:</b>	1	4	1	1

### ◆ Installation Tools

A Phillips screwdriver (M3, M3.5 to M6 metric or #1, #2 U.S. standard </>) is required to install the option.

</> Screw sizes vary by drive capacity. Select a screwdriver that matches the drive capacity.

**Note:** Tools required to prepare the option cables for wiring are not listed in this manual.

# 4 Option Components

### ◆ SI-EM3/V Option

Option with cover attached

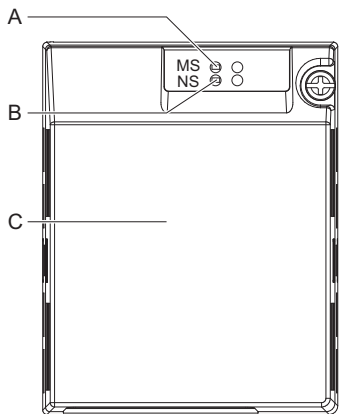

Option with cover removed

Underside

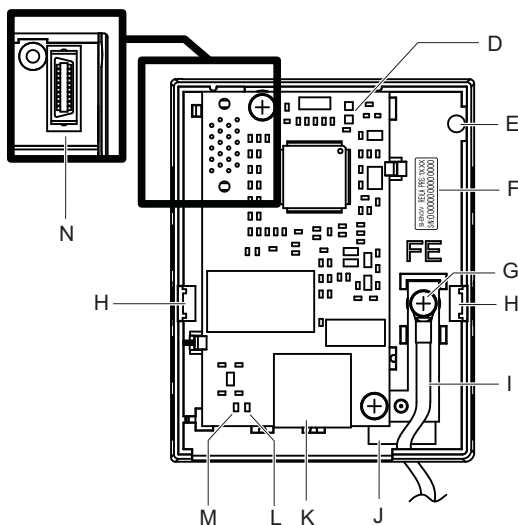

A – LED (MS)

B – LED (NS)

C – Option cover

D – Modbus TCP/IP PCB

E – Screw hole (attaching option cover)

F – Nameplate

G – Functional Earth cable connection (FE)

H – Mounting tabs

I – Ground wire <1>

J – Pass-through hole for wire

K – Communication connector CN1 (RJ45)

L – LED (LINK/ACT) <2>

M – LED (10/100) <2>

N – Option connector

<1> Ground wires are packaged loose inside the option packaging and must be connected during installation.

<2> Refer to [Option LED Display on page 16](#) for details on the LEDs.

Figure 1 Option Unit

### ◆ Dimensions

The installed option adds 27 mm (1.06 in.) to the total depth of the drive.

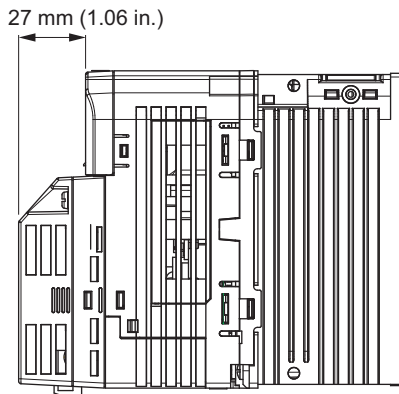

**Figure 2 Dimensions**

## 4 Option Components

---

### ◆ Communication Connector CN1

The communication connector on the option is a modular RJ45 female connector designated CN1.

CN1 is the connection point for a customer supplied male Modbus network communication cable.

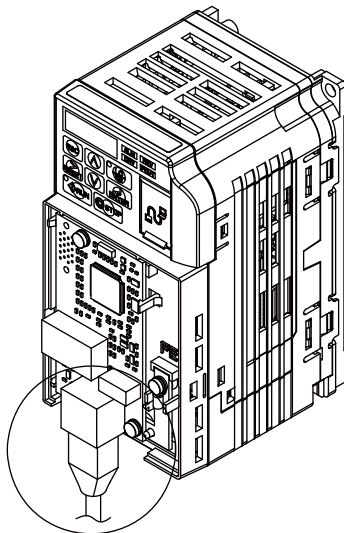
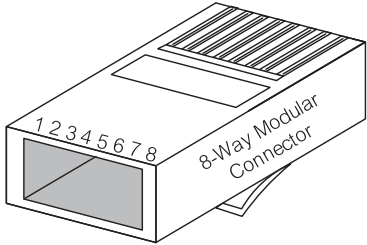

Figure 3 Communication connector CN1 (RJ45)

**Table 3 Male, 8-way Ethernet Modular Connector (Customer Supplied)**

Male Ethernet 8-Way Modular Connector	Pin	Description
	1 (Pair 2)	Transmit data (TXD) +
	2 (Pair 2)	Transmit data (TXD) -
	3 (Pair 3)	Receive data (RXD) +
	4 (Pair 1)	Not used </>
	5 (Pair 1)	Not used </>
	6 (Pair 3)	Receive data (RXD) -
	7 (Pair 4)	Not used </>
	8 (Pair 4)	Not used </>

</> Not used for 10 Mbps and 100 Mbps networks.

## 4 Option Components

### ◆ Option LED Display

The option has four LEDs:

#### Bi-color Status LEDs:

- Module status (MS) red/green
- Network status (NS) red/green

#### Green Ethernet LEDs:

- Network speed-10/100 (MS) green
- Link status and network activity-Link/Act (NS) red/green

The operational states of the option LEDs after the power-up diagnostic LED sequence is completed are described in [Table 4](#). Wait at least 2 seconds for the power-up diagnostic process to complete before verifying the states of the LEDs.

**Table 4 Option LED States**

Name	Indication		Operating Status	Description
	Color	Status		
MS	–	OFF	Power supply OFF	Power is not being supplied to the drive
	Green	ON	Option operating	The option is operating normally
	Green	Flashing	Option initializing	The option is configuring an IP address
	Red	ON	Fatal error occurred	The option has detected a fatal (unrecoverable) error
	Red	Flashing	Non-fatal error occurred	The option has detected a non-fatal (recoverable) error
NS	–	OFF	Offline or power supply OFF	–
	Green	ON	Online communications established	The option is online and has established connections
	Green	Flashing	Control connection active	The option is online and has an established and active control connection.
	Red	ON	Communications error (fatal)	The option detected a duplicate IP address
10/100 <I>	Green	OFF	10 Mbps is established	–
	Green	ON	100 Mbps is established	
LINK/ACT <I>	Green	OFF	Link is not established	
	Green	ON	Link is established	
	Green	Flashing	Link is established and there is network activity	

<I> Remove the cover for the option unit to check the status of the LED. Be careful not to touch the main circuit terminals or the control board in the drive.



## 5 Installation Procedure

### ◆ Section Safety

#### DANGER

##### Electrical Shock Hazard

Disconnect all power to the drive, wait at least five minutes after all indicators are off, measure the DC bus voltage to confirm safe level, and check for unsafe voltages before servicing to prevent electric shock. The internal capacitor remains charged even after the power supply is turned off. The charge indicator LED will extinguish when the DC bus voltage is below 50 Vdc.

#### WARNING

##### Electrical Shock Hazard

**Do not remove option board cover while the power is on.**

Failure to comply could result in death or serious injury.

The diagrams in this section may include option units and drives without covers or safety shields to show details. Be sure to reinstall covers or shields before operating any devices. The option board should be used according to the instructions described in this manual.

**Do not allow unqualified personnel to perform work on the drive or option.**

Failure to comply could cause death or serious injury.

Only authorized personnel familiar with installation, adjustment, and maintenance of AC drives and options may perform work.

## 5 Installation Procedure

### WARNING

**Do not use damaged wires, stress the wiring, or damage the wire insulation.**

Failure to comply could cause death or serious injury.

#### **Fire Hazard**

**Tighten all terminal screws to the specified tightening torque.**

Loose or overtightened connections could cause erroneous operation and damage to the terminal block or start a fire and cause death or serious injury.

### NOTICE

#### **Damage to Equipment**

**Observe proper electrostatic discharge (ESD) procedures when handling the option, drive, and circuit boards.**

Failure to comply could cause ESD damage to circuitry.

**Never connect or disconnect the motor from the drive while the drive is outputting voltage.**

Improper equipment sequencing could damage the drive.

**Do not connect or operate any equipment with visible damage or missing parts.**

Failure to comply could further damage the equipment.

**Do not use unshielded wire for control wiring.**

Failure to comply may cause electrical interference resulting in poor system performance. Use shielded, twisted-pair wires and ground the shield to the ground terminal of the drive.

**Properly connect all pins and connectors on the option and drive.**

Failure to comply could prevent proper operation and damage equipment.

**Confirm that all connections are correct after installing the option and connecting peripheral devices.**

Failure to comply could damage the option.

### ◆ Prior to Installing the Option

Prior to installing the option, wire the drive, make necessary connections to the drive terminals, and verify that the drive functions normally without the option installed. Refer to the Quick Start Guide packaged with the drive for information on wiring and connecting the drive.

### ◆ Installing the Option

Refer to the instructions below to install the option.

**DANGER!** *Electrical Shock Hazard. Do not connect or disconnect wiring while the power is on. Failure to comply could result in death or serious injury. Before installing the option, disconnect all power to the drive. The internal capacitor remains charged even after the power supply is turned off. The charge indicator LED will extinguish when the DC bus voltage is below 50 Vdc. To prevent electric shock, wait at least five minutes after all indicators are off and measure the DC bus voltage level to confirm safe level.*

1. Shut off power to the drive, wait at least five minutes after confirming the DC bus voltage is safe, then loosen the screw that fastens the front cover in place and remove the front cover. This drive front cover will be replaced by the option cover. Cover removal varies depending on drive size.

**NOTICE:** *Damage to Equipment. Observe proper electrostatic discharge procedures (ESD) when handling the option, drive, and circuit boards. Failure to comply may result in ESD damage to circuitry.*

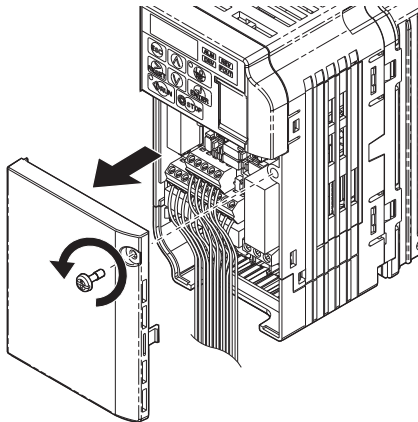

Figure 4 Remove Front Cover

## 5 Installation Procedure

- The remaining installation steps differ based on drive model. Find the drive model number on the drive nameplate and refer to the step indicated in [Table 5](#) based on your model number.

**Table 5 Installation Steps Based on Drive Model**

Enclosure Type	Drive Model	Proceed to Step	Page
IP20/Open-Chassis	CIMR-V□□A□□□□□B	<a href="#">3.</a>	<a href="#">20</a>
IP20/NEMA Type 1 <1>	CIMR-V□□A□□□□□F	<a href="#">6.</a>	<a href="#">22</a>

<1> Installing the option on an IP20/NEMA Type 1 enclosure drive voids NEMA Type 1 protection while maintaining IP20 conformity.

- For IP20/Open-Chassis models CIMR-V□□A□□□□□B, Remove the bottom cover of the drive by applying pressure to the tabs on each side of the bottom cover. Pull the bottom cover away from the drive while pushing in on the tabs to release the cover from the drive. Refer to [Figure 5](#) for details. Refer to [Figure 6](#) for drive models CIMR-V□□BA0006B to BA0018B, 2A0008B to 2A0069B, and 4A0001B to 4A0038B, which require removing the terminal cover prior to removing the bottom cover.

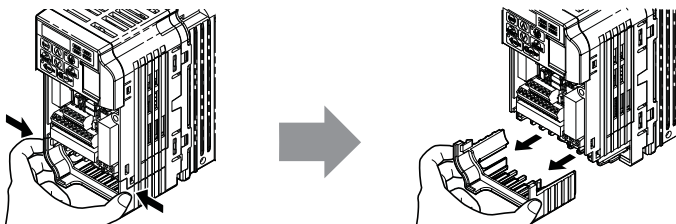

**Figure 5 Remove the Bottom Cover on an IP20/Open-Chassis Drive (Models CIMR-V□□BA0001B to BA0003B and 2A0001B to 2A0006B)**

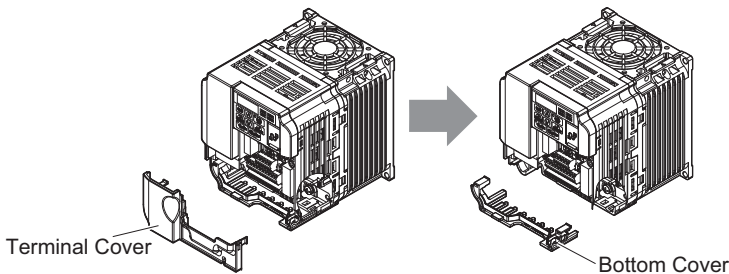

**Figure 6 Remove the Terminal Cover and Bottom Cover on an IP20/Open-Chassis Drive (Models CIMR-V□□BA0006B to BA0018B; 2A0008B to 2A0069B; 4A0001B to 4A0038B)**

4. On IP20/Open-Chassis models, connect the drive side of the ground wire to the drive ground terminal.

**Note:** The four different ground wires packaged with the option connect the option to different drive models. Select the proper ground wire depending on drive size. Refer to [Table 6](#) on page 21 for ground wire selection by drive model.

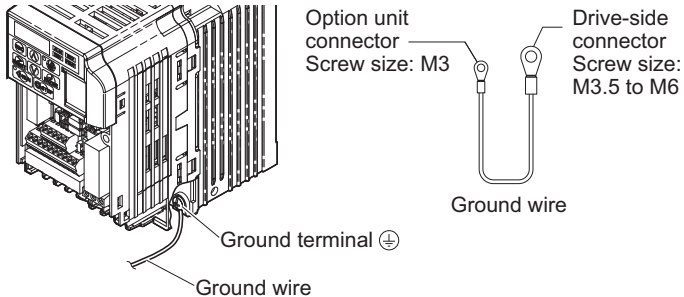

**Figure 7** Connect the Ground Wire on an IP20/Open-Chassis Drive

**Table 6** Ground Wire Selection

Ground Wire Length mm (in)	Drive Model CIMR-V□		
	Single-Phase 200 V Class	Three-Phase 200 V Class	Three-Phase 400 V Class
150 (5.9)	BA0001 BA0002 BA0003	2A0001 2A0002 2A0004 2A0006	–
200 (7.9)	BA0006 BA0010 BA0012 BA0018	2A0010 2A0012 2A0020	4A0001 4A0002 4A0004 4A0005 4A0007 4A0009 4A0011
250 (9.8)	–	2A0030 2A0040	4A0018 4A0023
400 (15.7)	–	2A0056 2A0069	4A0031 4A0038

5. For IP20/Open-Chassis models, go to Step 9. on page 24.

## 5 Installation Procedure

6. For IP20/NEMA Type 1 enclosure models CIMR-V□□A□□□□□F, loosen the screw on the front of the NEMA Type 1 terminal cover and remove it from the drive. Refer to [Figure 8](#) for details.

Refer to [Figure 9](#) for drive models CIMR-V□BA0006F to BA0018F, 2A0008F to 2A0069F, and 4A0001F to 4A0038F, which require removing the plastic terminal cover prior to removing the NEMA Type 1 terminal cover.

**Note:** Installing the option on an IP20/NEMA Type 1 enclosure drive voids NEMA Type 1 protection while maintaining IP20 conformity.

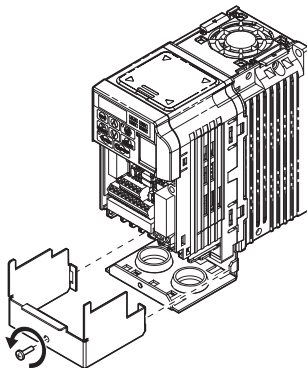

Figure 8 Remove the NEMA Type 1 Terminal Cover (CIMR-V□BA0001F to BA0003F, 2A0001F to 2A0006F)

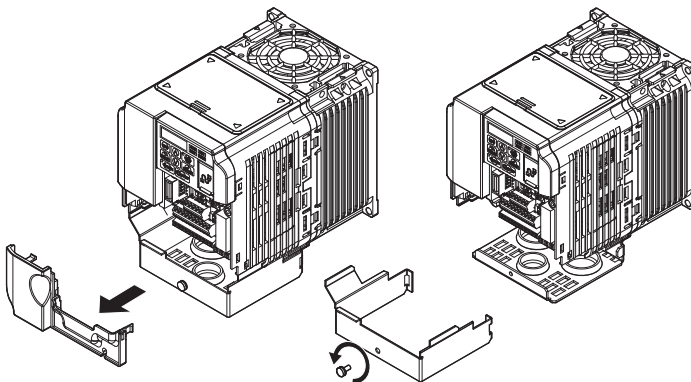
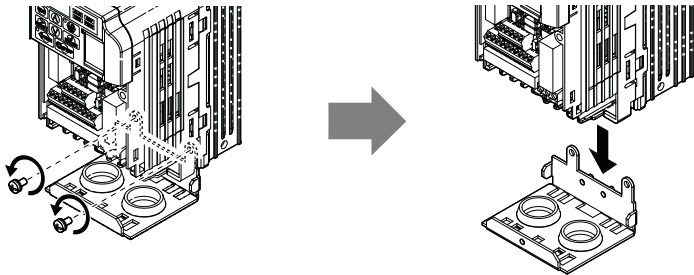

Figure 9 Remove the Terminal Cover on an IP20/NEMA Type 1 Drive (Models CIMR-V□BA0006F to BA0018F; 2A0008F to 2A0069F; 4A0001F to 4A0038F)

7. For models CIMR-V□BA0001F to BA0003F, 2A0001F to 2A0006F, loosen the screws attaching the NEMA Type 1 conduit bracket to the drive to remove the bracket.



**Figure 10 Remove the NEMA Type 1 Conduit Bracket**

8. On NEMA Type 1 enclosure models (CIMR-V□BA0001F to BA0003F, 2A0001F to 2A0006F), the screw for the drive ground terminal also acts as one of the screws that attaches the NEMA Type 1 conduit bracket to the drive. Reattach the NEMA Type 1 conduit bracket according to [Figure 11](#) and connect the drive-side of the ground wire to the drive ground terminal.

**Note:** The four different ground wires packaged with the option connect the option to different drive models. Select the proper ground wire depending on drive size. Refer to [Table 6](#) on page [21](#) for ground wire selection by drive model.

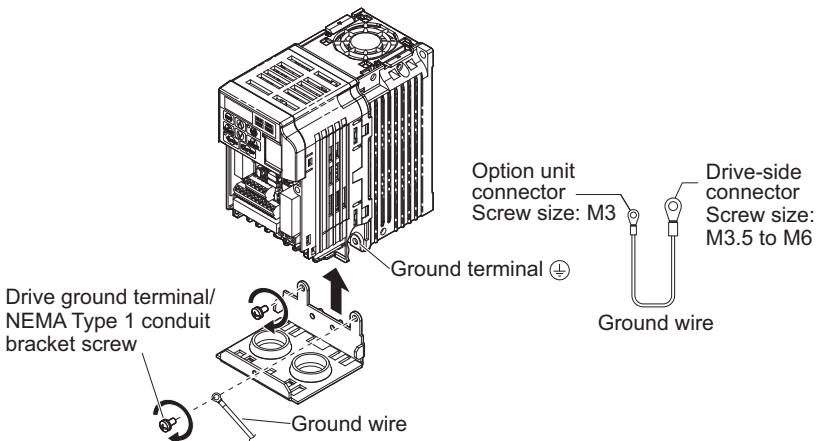

**Figure 11 Reattach the NEMA Type 1 Conduit Bracket and Connect the Ground Wire for models CIMR-V□BA0001F to BA0003F, 2A0001F to 2A0006F**

## 5 Installation Procedure

9. Reattach the bottom cover. Keep the ground wire inside of the bottom cover when reattaching.

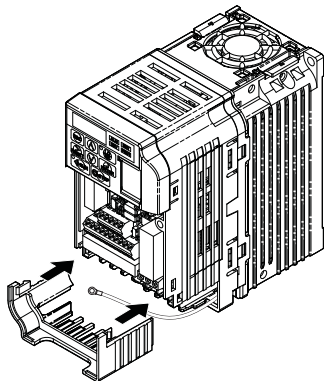

IP20/Open-Chassis

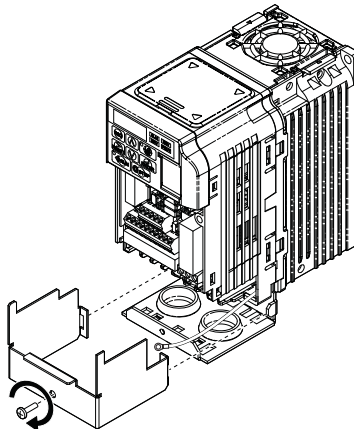

IP20/NEMA Type 1 Enclosure

**Figure 12 Reattach the Bottom Cover**



- 10.** On models CIMR-V□BA0006□ to BA0018□, 2A0008□ to 2A0069□, and 4A0001□ to 4A0038□, reattach the terminal cover. Refer to [Figure 13](#) and [Figure 14](#) for drive models CIMR-V□BA0006□ to BA0018□, 2A0008□ to 2A0020□, and 4A0001□ to 4A0011□, which require routing the ground wire through the provided notch when reinstalling the terminal cover.

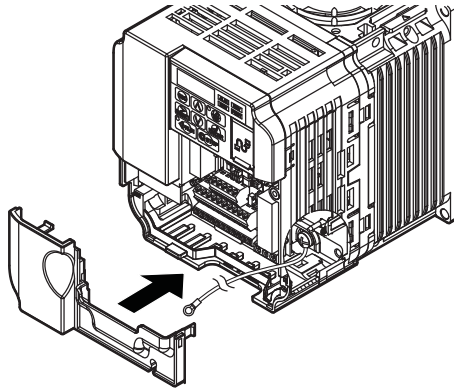

**Figure 13 Reattach the Terminal Cover**  
(Models CIMR-V□BA0006□ to BA0018□; 2A0008□ to 2A0069□; 4A0001□ to 4A0038□)

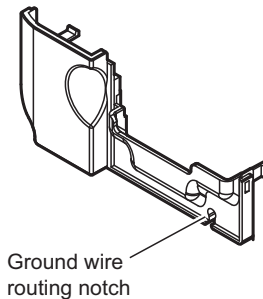

**Figure 14 Terminal Cover Ground Wire Notch**  
(Models CIMR-V□BA0006□ to BA0018□; 2A0008□ to 2A0020□; 4A0001□ to 4A0011□)

## 5 Installation Procedure

11. Remove the option cover and pass the ground wire through the inside of the drive bottom cover and into the through-hole for the ground wire at the front of the option.

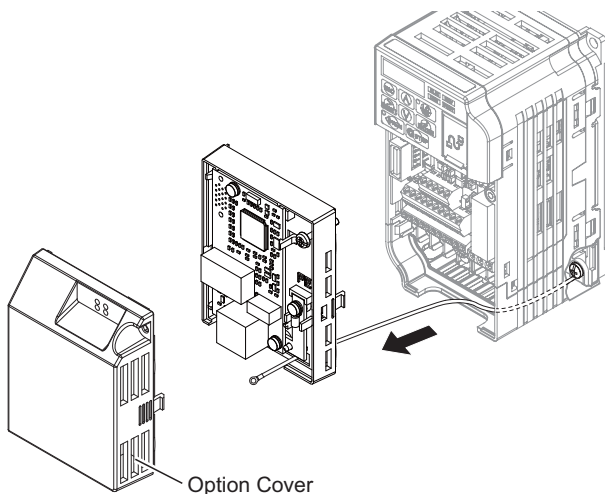

Figure 15 Ground Wire Routing

12. Attach the option to the drive. Properly seat the tabs on the left and right sides of the option to the drive case.

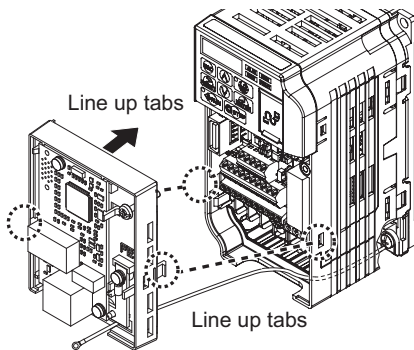
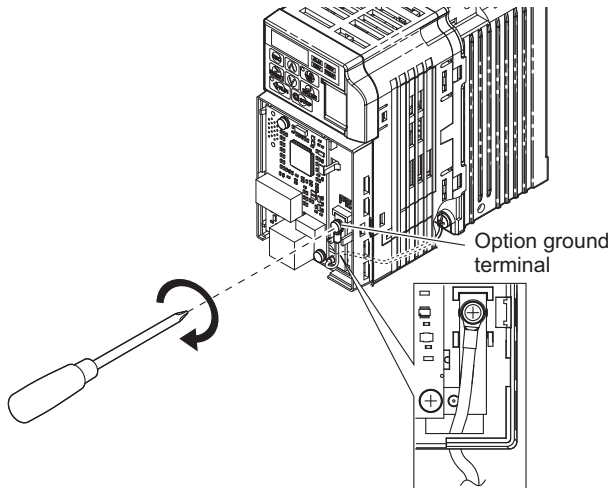

Figure 16 Connect the Option

13. Connect the ground wire at the option ground terminal. Tighten the screw to 0.5 to 0.6 N·m (or 4.4 to 5.3 in lbs) using an M3 Phillips screwdriver.



**Figure 17 Connect the Ground Wire to the Option**

14. To connect the option to a network, firmly connect RJ45 8-pin Shielded Twisted Pair Cat 5e cable(s) into the modular connector port.

**Note:** Do not connect or disconnect the communication cable while the drive is powered up or while the drive is in operation. Failure to comply may cause a static discharge, which will cause the option card to stop working properly. Cycle power on the drive and option card to reestablish functionality.

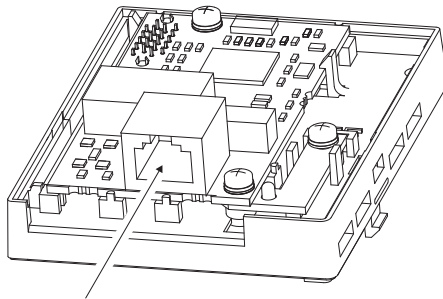

**Figure 18 Communication Cable Port**

## 5 Installation Procedure

### Communication Cable Specifications

Only use cables recommended for Modbus TCP/IP. Using a cable not specifically recommended may cause the option or drive to malfunction.

The use of CAT5e or equivalent Shielded Twisted Pair (STP) cable is recommended.

### Connection Diagram

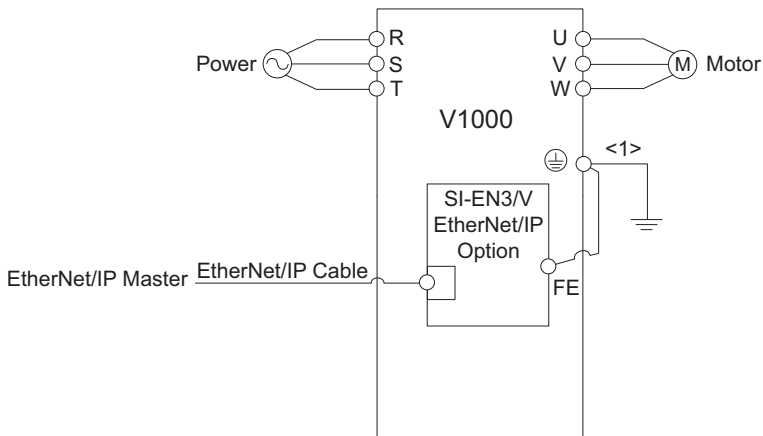

<1> The ground wire provided in the option shipping package must be connected during installation.

**Figure 19 Wiring Diagram**

15. Attach the option cover by aligning the tabs with the mounting holes, seat the front cover into place, and tighten the screw on the front.

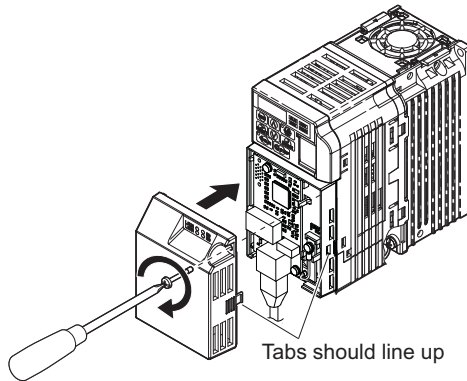

**Figure 20 Attach the Option Cover**

**Note:** Take proper precautions when wiring the option so that the front covers will easily fit back onto the drive. Make sure no cables are pinched between the front covers and the drive when replacing the covers.

16. Set drive parameters in Table 6 for proper option performance.

# 6 Related Drive Parameters

The parameters in [Table 7](#) set the drive for operation with the option. Confirm proper setting of all parameters in [Table 7](#) before starting network communications. Refer to the manual packaged with the drive for details on setting parameters.

**Table 7 Related Parameter Settings**

No. (Addr. H)	Name	Description	Values
b1-01 (180) </>	Reference 1 Source	Selects the input method for frequency reference. 0: Keypad 1: Analog Input 2: Memobus/Modbus Communications 3: Option PCB 4: Pulse Train Input	Default: 1 Range: 0 to 4 (Set to 3)
b1-02 (181) </>	Run Command 1 Source	Selects the input method for the Run command. 0: Keypad 1: Digital Input 2: Memobus/Modbus Communications 3: Option PCB	Default: 1 Range: 0 to 3 (Set to 3)
F6-01 (3A2)	Communication Error Selection	Selects drive response when a bUS error is detected during communications with the option. 0: Ramp to Stop 1: Coast to Stop 2: Fast Stop (Use C1-09) 3: Alarm Only </> 4: Alarm - Run at d1-04 5: Alarm - Ramp to Stop	Default: 1 Range: 0 to 5 </>
F6-02 (3A3)	Comm External Fault (EF0) Detect	Selects the condition for external fault detection (EF0). 0: Always detected 1: Detection during run only	Default: 0 Range: 0, 1
F6-03 (3A4)	Comm External Fault (EF0) Select	Selects drive response for external fault input (EF0) detection during option communications. 0: Ramp to Stop 1: Coast to Stop 2: Fast Stop (Use C1-09) 3: Alarm Only </>	Default: 1 Range: 0 to 3
F6-07 (3A8)	MultiStep Ref Priority Select	0: MultiStep References Disabled 1: MultiStep References Enabled	Default: 1 Range: 0, 1
F6-08 (36A)	Comm Parameter Reset @Initialize	Selects whether communication-related parameters F6-□□ and F7-□□ are set back to original default values when the drive is initialized using parameter A1-03. 0: No Reset - Parameters retained 1: Reset - Back to factory default Note: The setting value is not changed even when F6-08 is set to 1 and the drive is initialized using A1-03.	Default: 0 Range: 0, 1

## 6 Related Drive Parameters

No. (Addr. H)	Name	Description	Values
F6-15 (B5B)	Comm. Option Parameter Upgrade Selection	Selects whether F6-□□/□□/□□ communication-related parameters changed are enabled. 0: Enabled by Cycling the Power 1: Enabled F6-□□/□□ 2: Disabled F6-□□/□□ Note: F6-15 is reset to 0 after setting to 1 or 2.	Default: 0 Range: 0 to 2
F7-01 (3E5) <><> <>	IP Address 1	Sets the static/fixed IP address. Parameter F7-01 sets the most significant octet.	Default: 192 Min: 0 Max: 255
F7-02 (3E6) <><> <>	IP Address 2	Sets the static/fixed IP address. Parameter F7-02 sets the second most significant octet.	Default: 168 Min: 0 Max: 255
F7-03 (3E7) <><> <>	IP Address 3	Sets the static/fixed IP address. Parameter F7-03 sets the third most significant octet.	Default: 1 Min: 0 Max: 255
F7-04 (3E8) <><> <>	IP Address 4	Sets the static/fixed IP address. Parameter F7-04 sets the fourth most significant octet.	Default: 20 Min: 0 Max: 255
F7-05 (3E9) <>	Subnet Mask 1	Sets the static/fixed Subnet Mask. Parameter F7-05 sets the most significant octet.	Default: 255 Min: 0 Max: 255
F7-06 (3EA) <>	Subnet Mask 2	Sets the static/fixed Subnet Mask. Parameter F7-06 sets the second most significant octet.	Default: 255 Min: 0 Max: 255
F7-07 (3EB) <>	Subnet Mask 3	Sets the static/fixed Subnet Mask. Parameter F7-07 sets the third most significant octet.	Default: 255 Min: 0 Max: 255
F7-08 (3EC) <>	Subnet Mask 4	Sets the static/fixed Subnet Mask. Parameter F7-08 sets the fourth most significant octet.	Default: 0 Min: 0 Max: 255
F7-09 (3ED) <>	Gateway Address 1	Sets the static/fixed Gateway address. Parameter F7-09 sets the most significant octet.	Default: 192 Min: 0 Max: 255
F7-10 (3EE) <>	Gateway Address 2	Sets the static/fixed Gateway address. Parameter F7-10 sets the second most significant octet.	Default: 168 Min: 0 Max: 255

## 6 Related Drive Parameters

No. (Addr. H)	Name	Description	Values
F7-11 (3EF) <5>	Gateway Address 3	Sets the static/fixed Gateway address. Parameter F7-11 sets the third most significant octet.	Default: 1 Min: 0 Max: 255
F7-12 (3E0) <5>	Gateway Address 4	Sets the static/fixed Gateway address. Parameter F7-12 sets the fourth most significant octet.	Default: 1 Min: 0 Max: 255
F7-13 (3F1)	Address Mode at Startup	Selects how the option address is set. 0: Static 1: BOOTP 2: DHCP	Default: 2 Range: 0 to 2
F7-14 (3F2)	Duplex Mode Selection	Selects duplex mode setting. 0: Auto/Auto 1: Half/Half 2: Full/Full 3: Half/Auto 4: Half/Full 5: Auto/Half 6: Auto/Full 7: Full/Half 8: Full/Auto	Default: <6> Range: 0 to 8
F7-15 (3F3) <7>	Communication Speed Selection	Sets the communication speed. 0: 10 Mbps (Available only with drive software version PRG: 1012 to 1015) 1: 10 Mbps 100: 100 Mbps	Default: <8> Range: <8>
F7-16 (3F4)	Timeout Value	Sets the time-out value for communication loss detection in tenths of a second. A value of 0 disables the connection time-out. Example: An entered value of 100 represents 10.0 seconds.	Default: 0.0 Min: 0.0 Max: 30.0
H5-11 (43C)	Communications ENTER Function Selection	Selects whether an Enter command is necessary to change parameter values via MEMOBUS/Modbus communications. 0: Parameter changes are activated when ENTER command is written 1: Parameter changes are activated immediately without use of ENTER command	Default: 1 Range: 0, 1

- <1> Set b1-02 = 3 to start and stop the drive with the Modbus TCP/IP master device using serial communications.  
Set b1-01 = 3 to control the frequency reference of the drive via the master device.
- <2> Setting this parameter to 3 will cause the drive to continue operation after detecting a fault. Take proper measures such as installing an emergency stop switch when using setting 3.
- <3> Cycle power for setting changes to take effect.
- <4> If F7-13 is set to 0, then all IP Addresses (F7-01 to F7-04) must be unique.
- <5> Set F7-01 to F7-12 when F7-13 is set to 0.
- <6> Default setting differs by drive software version.  
1012 to 1015: 0  
≥1016: 1
- <7> Set F7-15 when F7-14 is set to 0 or 2.



<8> The setting values differ by drive software version.

1012 to 1015  
 Default: 0  
 Range: 0, 10, 100  
 ≥1016  
 Default: 10  
 Range: 10, 100

**Table 8 Option Monitors**

No.	Name	Description	Range
U6-80 to U6-83	OPT IP ADR 1 to 4	Displays IP Address currently available; <ul style="list-style-type: none"> <li>• U6 -80: First octet</li> <li>• U6 -81: Second octet</li> <li>• U6 -82: Third octet</li> <li>• U6 -83: Forth octet</li> </ul>	0 to 255
U6-84 to U6-87	Online Subnet 1 to 4	Displays subnet currently available; <ul style="list-style-type: none"> <li>• U6 -84: First octet</li> <li>• U6 -85: Second octet</li> <li>• U6 -86: Third octet</li> <li>• U6 -87: Forth octet</li> </ul>	0 to 255
U6-88 to U6-91	Online Gateway	Displays gateway currently available; <ul style="list-style-type: none"> <li>• U6 -88: First octet</li> <li>• U6 -89: Second octet</li> <li>• U6 -90: Third octet</li> <li>• U6 -91: Forth octet</li> </ul>	0 to 255
U6-92	Online Speed	Displays CN1 Port 1 link speed currently available.	10: 10 Mbps 100: 100 Mbps
U6-93	Online Duplex	Displays CN1 Port 1 duplex setting currently available.	0: Half, 1: Full
U6-98	First Fault	Displays first option fault. Refer to <i>Option Fault Monitors U6-98 and U6-99 on page 45</i> for details.	–
U6-99	Current Fault	Displays current option fault. Refer to <i>Option Fault Monitors U6-98 and U6-99 on page 45</i> for details.	–

# 7 Modbus TCP/IP Messaging

### ◆ Modbus TCP/IP Overview

The Modbus TCP/IP protocol is essentially the Modbus protocol over an Modbus TCP/IP network. A master controller (typically a PLC) sends commands to slave devices, which then perform the specified functions and send a response to the master. The drive using the option has slave functionality.

### ■ Supported Modbus TCP/IP Commands

**Table 9 Supported Modbus TCP/IP Commands**

Function Code	Function Name
03H	Read Multiple Registers
06H	Write Single Register
10H	Write Multiple Registers
17H	Read/Write Multiple Registers

### ■ Drive Modbus TCP/IP Option Registers

All of the command registers, monitor registers, and parameters documented in the drive Technical Manual are accessible via the option.

### ■ High Speed Access Drive Modbus TCP/IP Option Registers

Many of the registers required for control have been specially mapped to provide higher speed access to increase network performance. Use these registers for the best response times.

All of the drive command registers have been mapped to this high speed access area (Modbus TCP/IP registers 01H to 01FH). In addition, the monitors shown in [Table 10](#) are mapped for high speed access.

**Table 10 Drive Registers**

Address (hex)	Drive Register (hex)	Description	Bit	Description
2000	4B	Status Word (U1-12)	0	During Run
			1	During Zero Speed
			2	During Reverse Direction
			3	During Fault Reset Signal Input
			4	During Speed Agree
			5	Drive Ready
			6	Alarm
			7	Fault
			8	During Operation Error (oPE□□)
			9	During Momentary Power Loss
			A	Motor 2 Selected
			B	Reserved
			C	Reserved
			D	Reserved
			E	ComRef Status, NetRef Status
F	ComCtrl Status, NetCtrl Status			
2001	44	Motor Speed Monitor (U1-05)		
2002	48	Torque Reference Monitor (U1-09)		
2003	F0	PG Count Channel 1		
2004	40	Frequency Reference Monitor (U1-01)		
2005	41	Output Frequency Monitor (U1-02)		
2006	26	Output Current (0.01 A units for drives set to 11 kW in Heavy or Normal Duty and 0.1 A units for drives set to 15 kW and above.)		
2007	4F	Terminal A2 Input Level Monitor (U1-14)		
2008	46	DC Bus Voltage Monitor (U1-07)		

## 7 Modbus TCP/IP Messaging

Address (hex)	Drive Register (hex)	Description	Bit	Description
2009	C0	Error Signal 1	0	Reserved
			1	Undervoltage (Uv1)
			2	Control Power Supply Undervoltage (Uv2)
			3	Soft Charge Circuit Fault (Uv3)
			4	Reserved
			5	Ground Fault (GF)
			6	Overcurrent (oC)
			7	Overvoltage (ov)
			8	Heatsink Overheat (oH)
			9	Heatsink Overheat (oH1)
			A	Motor Overload (oL1)
			B	Drive Overload (oL2)
			C	Overtorque Detection 1 (oL3)
			D	Overtorque Detection 2 (oL4)
			E	Dynamic Braking Transistor Fault (rr)
F	Braking Resister Overheat (rH)			
200A	C1	Error Signal 2	0	External Fault at input terminal S3 (EF3)
			1	External Fault at input terminal S4 (EF4)
			2	External Fault at input terminal S5 (EF5)
			3	External Fault at input terminal S6 (EF6)
			4	External Fault at input terminal S7 (EF7)
			5	Reserved
			6	Reserved
			7	Overspeed (os)
			8	Excessive Speed Deviation (dEv)
			9	PG Disconnected (PGo)
			A	Input Phase Loss (PF)
			B	Output Phase Loss (LF)
			C	Motor Overheat (PTC input) (oH3)
			D	Digital Operator Connection Fault (oPr)
			E	EEPROM Write Error (Err)
F	Motor Overheat Fault (PTC input) (oH4)			

## 7 Modbus TCP/IP Messaging

Address (hex)	Drive Register (hex)	Description	Bit	Description
200B	C2	Error Signal 3	0	MEMOBUS/Modbus Communication Error (CE)
			1	Option Communication Error (bUS)
			2	Reserved
			3	Reserved
			4	Control Fault (CF)
			5	Reserved
			6	Option External Fault (EF0)
			7	PID Feedback Loss (FbL)
			8	Undertorque Detection 1 (UL3)
			9	UL4 Undertorque Detection 2 (UL4)
			A	High Slip Braking Overload (oL7)
			B	Reserved
			C	Reserved
			D	Reserved
E	Reserved			
F	Hardware Fault (includes oF□)			
200C	4E	Terminal A1 Input Level Monitor (U1-13)		
200D	49	Digital Input Terminal Status (U1-10)		
200E	50	Terminal A3 Input Level Monitor (U1-15)		
200F	F1	PG Count Channel 2		
2010	4D	Drive Software Number (Flash) (U1-25)		

## 7 Modbus TCP/IP Messaging

### ◆ Enter Command Types

The drive supports two types of Enter Commands as shown in the table below. An Enter Command is enabled by writing 0 to register number 0900H or 0910H.

#### ■ Enter Commands

**Table 11 Enter Command Types**

Register Number	Description
0900H	Writes data into the EEPROM (non-volatile memory) of the drive and enables the data to RAM at the same time. Parameter changes remain even if the power supply is cycled.
0910H	Writes data in the RAM only. Parameter changes are lost when the drive is shut off.

**Note:** Because the EEPROM can be written to a maximum of 100,000 times, refrain from frequently writing to the EEPROM. An Enter Command is not required if reference or broadcast data are sent to the drive.

### ◆ Enter Command Settings

When replacing earlier Yaskawa drive models with a 1000 Series drive and keeping the MEMOBUS/Modbus communications settings, parameter H5-11 needs to be set in accordance with how the Enter Command functions in the older drive. H5-11 determines if an Enter Command is needed or not in order to activate parameter changes in the drive.

- If upgrading from a G7 or F7 series drive to 1000 Series, set parameter H5-11 to 0.
- If upgrading from a V7 series drive to 1000 Series, set parameter H5-11 to 1.

#### ■ H5-11 and the Enter Commands

**Table 12 Enter Command Types**

H5-11 Settings	H5-11 = 0	H5-11 = 1
Drive being replaced.	G7, F7	V7
How parameter settings are enabled.	When the Enter Command is received from the master.	As soon as the value is changed.
Upper/lower limit check.	Upper/lower limit check is performed taking the settings of related parameters into account.	The upper/lower limit of the changed parameter is checked only.
Default value of related parameters.	Not affected. The settings of related parameters remain unchanged. Parameters must be changed manually if needed.	The default settings of related parameters are changed automatically.
Error handling when setting multiple parameters.	Data is accepted even if one setting is invalid. The invalid setting will be discarded. No error message occurs.	Error occurs if only one setting is invalid. All data sent is discarded.

## 8 Web Interface

The web server interface to the drive option allows management of diagnostic information through a standard web browser. The embedded web pages include:

- Main page (Information)
- Drive Status page (Status, Monitor and Fault History)
- Network Monitor page (Network Monitor)

### ◆ Main Page (Information)

The embedded main page shows basic option information such as IP address, MAC address, and firmware version. This page also shows the status of the option and provides links to the other embedded web pages.

**YASKAWA**

Information

Protocol:	Modbus/TCP
IP Address:	192.168.1.120
MAC ID:	00:20:B5:24:22:75
Product Name:	SI-EM3
Option Firmware Version:	VST800243
Drive Model:	CIMR-VU2A0006
Drive Firmware Version:	1016

Main Status

✓

Main Menu

Welcome to the Yaskawa Modbus/TCP Web Interface

Please choose from the following options:



**Status & Monitor**

Monitor Drive Signals



**Network**

Network Status Monitor

Copyright © 2011 Yaskawa

Figure 21 Main Page View

## 8 Web Interface

### ◆ Drive Status Page (Status, Monitor and Fault History)

The embedded drive status page shows basic I/O information and drive state information.

**YASKAWA**

Status, Monitor and Fault History

**Drive Signals**

Stopped	On	Forward	On	Alarm	Off
Running	Off	Reverse	Off	Fault	Off

---

Drive Signals		Multi-function Inputs		Multi-function Outputs	
Frequency Ref.	0.00 Hz	Terminal S1	Off	Output MA/MB-MC	Off
Output Frequency	0.00 Hz	Terminal S2	Off	Output P1 - PC	Off
Output Current	0.0 A.	Terminal S3	Off	Output P2 - PC	Off
DC Bus Voltage	316 VDC	Terminal S4	Off		
Torque Ref	NA %	Terminal S5	Off		
		Terminal S6	Off		
		Terminal S7	Off		
		Terminal S8	NA		
		Terminal S9	NA		
		Terminal S10	NA		
		Terminal S11	NA		
		Terminal S12	NA		

---

**Analog Input Signals**

Input Terminal A1	43.3 %
-------------------	--------

---

**Fault Information**

Active: None

Copyright © 2011 Yaskawa

Figure 22 Drive Status Page View



## ◆ Network Monitor Page (Network Monitor)

The embedded network monitor page shows the status of the option network traffic and open I/O connections.

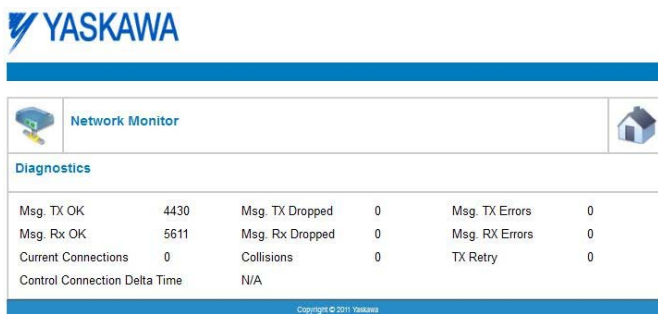

**Figure 23 Network Monitor Page View**  
**Table 13 Network Monitor Explanations**

Network Monitor	Explanation
Msg Tx OK	Cumulative number of messages transmit successfully from the option.
Msg Rx OK	Cumulative number of messages received successfully to the option.
Current Connections	Current number of open connections.
Control Connection Delta Time	The time between the last two writes to the Control register, MEMOBUS/Modbus address 0001H.
Msg Tx Dropped	Cumulative number of messages dropped due to output network buffer being full and unable to hold the new message.
Msg Rx Dropped	Cumulative number of messages dropped due to input network buffer being full and unable to hold the new message.
Collisions	Cumulative number of collisions (half duplex only) reported by the MAC/PHY (Media Access Control/Physical Connection).
Msg Tx Errors	Cumulative number of transmit underruns and transmit stops reported by the MAC/PHY.
Msg Rx Errors	Cumulative number of receive overruns, receive stops, and receive error frames reported by the MAC/PHY.
Tx Retry	Cumulative number of transmits in which the 1st attempt was delayed due to busy medium reported by the MAC/PHY.

**Note:** Cumulative counters are reset when the power supply is cycled.

# 9 Troubleshooting

### ◆ Drive-Side Error Codes

Drive-side error codes appear on the drive keypad. [Table 14](#) lists causes of the errors and possible corrective actions. Refer to the drive Technical Manual for additional error codes that may appear on the drive digital operator.

### ■ Faults

Both bUS (Option communication error) and EF0 (Option Card External Fault) can appear as an alarm or as a fault. When a fault occurs, the digital operator ALM LED remains lit. When an alarm occurs, the ALM LED flashes.

If communication stops while the drive is running, use the following questions as a guide to help remedy the fault:

- Is the option properly installed?
- Is the communication line properly connected to the option? Is it loose?
- Is the controller program working? Has the controller/PLC CPU stopped?
- Did a momentary power loss interrupt communications?

**Table 14 Fault Displays, Causes, and Possible Solutions**

Keypad Display		Fault Name
bUS	bUS	Option Communication Error.
		<ul style="list-style-type: none"> <li>• After establishing initial communication, the connection was lost.</li> <li>• Only detected when the run command or frequency reference is assigned to the option (b1-01 = 3 or b1-02 = 3).</li> </ul>
Cause		Possible Solutions
No signal was received from the PLC.	Faulty communications wiring	<ul style="list-style-type: none"> <li>• Check for faulty wiring.</li> <li>• Correct any wiring problems.</li> </ul>
An existing short circuit or communications disconnection		
A data error occurred due to electric interference.		<ul style="list-style-type: none"> <li>• Counteract noise in the control circuit, main circuit, and ground wiring.</li> <li>• If a magnetic contactor is identified as a source of noise, install a surge absorber to the contactor coil.</li> <li>• Use only recommended cables or other shielded line. Ground the shield on the controller side or the drive input power side.</li> <li>• Separate all communication wiring from drive power lines. Install an EMC noise filter to the drive power supply input.</li> <li>• Counteract noise in the master controller (PLC).</li> </ul>

The option is not properly connected to the drive.	Reinstall the option.
Option is damaged	If there are no problems with the wiring and the error continues to occur, replace the option.
Control Connection Time-out.	<ul style="list-style-type: none"> <li>• Option did not receive a command (write to Modbus address 01H) within the time-out period specified in parameter F7-16</li> <li>• Check value programmed in F7-16</li> <li>• Check if PLC program stopped running</li> </ul>
Duplicate IP Address	The option shares IP Address with at least one other node. Check the setting value of F7-03 and F7-04 (IP Address).

Keypad Display		Fault Name
<i>EF0</i>	EF0	Option Card External Fault
		The alarm function for an external device has been triggered.
Cause		Possible Solutions
An external fault was received from the PLC.		<ol style="list-style-type: none"> <li>1. Remove the cause of the external fault.</li> <li>2. Reset the external fault input from the PLC.</li> </ol>
Problem with the PLC program		Check the PLC program.

Keypad Display		Fault Name
<i>oFA00</i>	oFA00	Option Card Fault
		Option is not properly connected.
Cause		Possible Solutions
The option card installed into port CN5-A is incompatible with the drive.		Connect the option to the correct option port. Note: PG option cards are supported by option ports CN5-B and CN5-C only.

Keypad Display		Fault Name
<i>oFA01</i>	oFA01	Option Card Fault
		Option is not properly connected.
Cause		Possible Solutions
The option connected to option port CN5-A was changed during run.		De-energize the drive and plug the option into the drive according to <a href="#">Installation Procedure on page 17</a> .

## 9 Troubleshooting

Keypad Display		Fault Name
	oFA03	Option Card Fault
		Option self-diagnostics error.
Cause		Possible Solutions
The option card connection to port CN5-A is faulty.		<ol style="list-style-type: none"> <li>1. Turn off the power.</li> <li>2. Check if the option is properly plugged into the option port.</li> <li>3. Replace the option if the fault continues to occur.</li> </ol>

Keypad Display		Fault Name
	oFA04	Option Card Fault
		Option flash write mode.
Cause		Possible Solutions
The option card connection to port CN5-A is faulty.		<ol style="list-style-type: none"> <li>1. Turn off the power.</li> <li>2. Check if the option is properly plugged into the option port.</li> <li>3. Replace the option if the fault continues to occur.</li> </ol>

Keypad Display		Fault Name
	oFA30 to oFA43	Option Card Fault
		Communication ID error.
Cause		Possible Solutions
The option card connection to port CN5-A is faulty.		<ol style="list-style-type: none"> <li>1. Turn off the power.</li> <li>2. Check if the option is properly plugged into the option port.</li> <li>3. Replace the option if the fault continues to occur.</li> </ol>

### ■ Minor Faults and Alarms

Keypad Display		Minor Fault Name	
CALL	CALL	Serial communication transmission error Communication is not established.	
Cause		Possible Solutions	Minor Fault (H2-□□ = 10)
Communication wiring is faulty.		<ul style="list-style-type: none"> <li>• Check for wiring errors.</li> <li>• Correct the wiring.</li> </ul>	YES
An existing short circuit or communications disconnection		Check disconnected cables and short circuits and repair as needed.	
Programming error on the master side.		Check communications at start-up and correct programming errors.	
Communication circuitry is damaged.		<ul style="list-style-type: none"> <li>• Perform a self-diagnostics check</li> <li>• If the problem continues, replace either the control board or the entire drive. For instructions on replacing the control board, contact Yaskawa or your nearest sales representative.</li> </ul>	
Termination resistor of the MEMOBUS/Modbus communications is not enabled.		Set DIP switch S2 to the ON position to enable the termination resistor on a drive located at the end of a network line.	

### ■ Option Fault Monitors U6-98 and U6-99

The option can declare error/warning conditions via drive monitor parameters on the drive digital operator as shown in [Table 15](#).

**Table 15 Option Fault Monitor Descriptions**

Fault Condition	Fault Declared	Status Value (U6-98/U6-99)	Description
No Fault	n/a	0	No faults
Force Fault	EF0	3	Network sent a message to force this node to the fault state
Network Link Down	BUS ERROR	1200	No network link to the option
Connection Time-out	BUS ERROR	1201	The control connection timer (F7-16) timed out
Duplicate IP Address	BUS ERROR	1202	This node and at least one other node have the same IP address
Default MAC Address	None	1203	Factory default MAC Address programmed into the option. Contact a Yaskawa representative or the nearest Yaskawa sales office for details.

## 9 Troubleshooting

---

Two drive monitor parameters, U6-98 and U6-99, assist the user in network troubleshooting.

- U6-98 displays the first declared fault since the last power cycle. U6-98 is only cleared upon drive power-up.
- U6-99 displays the present option status. U6-99 is cleared upon a network-issued fault reset and upon power-up.

If another fault occurs while the original fault is still active, parameter U6-98 retains the original fault value and U6-99 stores the new fault status value.

## 10 European Standards



Figure 24 CE Mark

The CE mark indicates compliance with European safety and environmental regulations. It is required for engaging in business and commerce in Europe.

European standards include the Machinery Directive for machine manufacturers, the Low Voltage Directive for electronics manufacturers, and the EMC guidelines for controlling noise.

This option displays the CE mark based on the EMC guidelines.

### **EMC Guidelines: 2014/30/EU**

Drives used in combination with this option and devices used in combination with the drive must also be CE certified and display the CE mark. When using drives displaying the CE mark in combination with other devices, it is ultimately the responsibility of the user to ensure compliance with CE standards. Verify that conditions meet European standards after setting up the device.

---

### ◆ **EMC Guidelines Compliance**

This option is tested according to European standards EN 61800-3:2004+A1:2012 and complies with EMC guidelines. The CE marking is declared based on the harmonized standards.

### ■ **EMC Guidelines Installation Conditions**

Verify the following installation conditions to ensure that other devices and machinery used in combination with this option and drives also comply with EMC guidelines:

1. Use dedicated shield cable for the option and external device (encoder, I/O device, master), or run the wiring through a metal conduit.
2. Keep wiring as short as possible and ground the largest possible surface area of the shield to the metal panel according to [Figure 26](#).

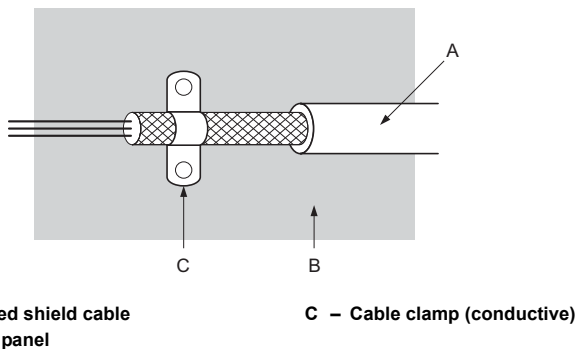

Figure 25 Ground Area

## ■ Option Installation for CE Compliance: Model SI-□□/V

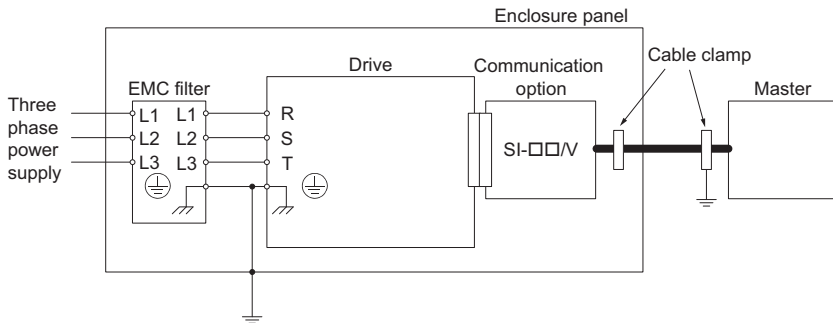

Figure 26 Option Installation for CE Compliance



# 11 Specifications

**Table 16 Option Specifications**

Item	Specifications
<b>Model</b>	SI-EM3/V
<b>Supported Messages</b>	<ul style="list-style-type: none"> <li>• Read Multiple Registers (03H)</li> <li>• Write Single Register (06H)</li> <li>• Write Multiple Registers (10H)</li> <li>• Read and Write Registers (17H)</li> </ul> Commands that support multiple registers have a maximum Read and Write size of 16 registers.
<b>Option Conformance</b>	Modbus-IDA Passed
<b>Connector Type</b>	RJ45 8-pin Shielded Twisted Pair Cat 5e cable
<b>Physical Layer Type</b>	Isolated Physical Layer
<b>IP Address Setting</b>	Programmable from drive keypad or network
<b>Communication Speed</b>	Programmable from drive keypad or network: 10/100 Mbps, auto-negotiate.
<b>Number of Connections</b>	Modbus TCP/IP: 10 Web Page Access: 2
<b>Duplex Mode</b>	Half-forced, Auto-negotiate, Full-forced
<b>Address Startup Mode</b>	Static, BOOTP, DHCP
<b>Ambient Temperature</b>	-10 °C to +50 °C (14 °F to 122 °F)
<b>Humidity</b>	95% RH or lower with no condensation
<b>Storage Temperature</b>	-20 °C to +60 °C (-4 °F to 140 °F) allowed for short-term transport of the product
<b>Area of Use</b>	Indoors and free from: <ul style="list-style-type: none"> <li>• Oil mist, corrosive gas, flammable gas, and dust</li> <li>• Radioactive materials or flammable materials, including wood</li> <li>• Harmful gas or fluids</li> <li>• Salt</li> <li>• Direct sunlight</li> <li>• Falling foreign objects</li> </ul>
<b>Altitude</b>	1000 m (3280 ft.) or lower

## 11 Specifications

---

### ◆ Revision History

Revision dates and manual numbers appear on the bottom of the back cover.

MANUAL NO.

TOBP C730600 59B <1>

Revision number

Published in Japan July 2017

Date of publication

Date of Publication	Revision Number	Section	Revised Content
July 2017	<1>	Front cover	Revision: Format
		All	Revision: Reviewed and corrected entire documentation.
		Chapter 2	Addition: Note in Table 1
		Back cover	Revision: Address, format
March 2012	–	–	First edition

# YASKAWA AC Drive-V1000 Option Modbus TCP/IP Installation Manual

---

## **DRIVE CENTER (INVERTER PLANT)**

2-13-1, Nishimiyachi, Yakuhashi, Fukuoka, 824-8511, Japan  
Phone: +81-930-25-2548 Fax: +81-930-25-3431  
<http://www.yaskawa.co.jp>

## **YASKAWA ELECTRIC CORPORATION**

New Pier Takeshiba South Tower, 1-16-1, Kaigan, Minatoku, Tokyo, 105-6891, Japan  
Phone: +81-3-5402-4502 Fax: +81-3-5402-4580  
<http://www.yaskawa.co.jp>

## **YASKAWA AMERICA, INC.**

2121, Norman Drive South, Waukegan, IL 60085, U.S.A.  
Phone: +1-800-YASKAWA (927-5292) or +1-847-887-7000 Fax: +1-847-887-7310  
<http://www.yaskawa.com>

## **YASKAWA ELÉTRICO DO BRASIL LTDA.**

777, Avenida Piraporinha, Diadema, São Paulo, 09950-000, Brasil  
Phone: +55-11-3585-1100 Fax: +55-11-3585-1187  
<http://www.yaskawa.com.br>

## **YASKAWA EUROPE GmbH**

Hauptstraße 185, 65760 Eschborn, Germany  
Phone: +49-6196-569-300 Fax: +49-6196-569-398  
<http://www.yaskawa.eu.com> E-mail: [info@yaskawa.eu.com](mailto:info@yaskawa.eu.com)

## **YASKAWA ELECTRIC KOREA CORPORATION**

35F, Three IFC, 10 Gukjegeumyung-ro, Yeongdeungpo-gu, Seoul, 07326, Korea  
Phone: +82-2-784-7844 Fax: +82-2-784-8495  
<http://www.yaskawa.co.kr>

## **YASKAWA ELECTRIC (SINGAPORE) PTE. LTD.**

151, Lorong Chuan, #04-02A, New Tech Park, 556741, Singapore  
Phone: +65-6282-3003 Fax: +65-6289-3003  
<http://www.yaskawa.com.sg>

## **YASKAWA ELECTRIC (THAILAND) CO., LTD.**

59, 1st-5th Floor, Flourish Building, Soi Ratchadapisek 18, Ratchadapisek Road, Huaykwang, Bangkok, 10310, Thailand  
Phone: +66-2-017-0099 Fax: +66-2-017-0799  
<http://www.yaskawa.co.th>

## **YASKAWA ELECTRIC (CHINA) CO., LTD.**

22F, One Corporate Avenue, No.222, Hubin Road, Shanghai, 200021, China  
Phone: +86-21-5385-2200 Fax: +86-21-5385-3299  
<http://www.yaskawa.com.cn>

## **YASKAWA ELECTRIC (CHINA) CO., LTD. BEIJING OFFICE**

Room 1011, Tower W3 Oriental Plaza, No. 1, East Chang An Ave.,  
Dong Cheng District, Beijing, 100738, China  
Phone: +86-10-8518-4086 Fax: +86-10-8518-4082

## **YASKAWA ELECTRIC TAIWAN CORPORATION**

12F, No. 207, Sec. 3, Beishin Rd., Shindian Dist., New Taipei City 23143, Taiwan  
Phone: +886-2-8913-1333 Fax: +886-2-8913-1513 or +886-2-8913-1519  
<http://www.yaskawa.com.tw>

## **YASKAWA INDIA PRIVATE LIMITED**

#17/A, Electronics City, Hosur Road, Bangalore, 560 100 (Karnataka), India  
Phone: +91-80-4244-1900 Fax: +91-80-4244-1901  
<http://www.yaskawaindia.in>

---

# YASKAWA

YASKAWA ELECTRIC CORPORATION

In the event that the end user of this product is to be the military and said product is to be employed in any weapons systems or the manufacture thereof, the export will fall under the relevant regulations as stipulated in the Foreign Exchange and Foreign Trade Regulations. Therefore, be sure to follow all procedures and submit all relevant documentation according to any and all rules, regulations and laws that may apply. Specifications are subject to change without notice for ongoing product modifications and improvements.

© 2012 YASKAWA ELECTRIC CORPORATION

MANUAL NO.

TOBP C730600 59B <1>

Published in Japan July 2017  
17-4-18